



<b>Engine</b>	Cummins QSL9.3
<b>Rated Power</b>	180 kW (241 hp / 245 ps) @ 2,200 rpm
<b>Rated Net Power</b>	168 kW (225 hp / 228 ps) @ 2,200 rpm
<b>Operating Weight</b>	20,386 kg
<b>Standard Bucket Size</b>	4.0 m <sup>3</sup>
<b>Standard Breakout Force</b>	178 kN
<b>Standard Dump Clearance</b>	3,303 mm

# 862H WHEEL LOADER

# 862H SPECIFICATIONS >>>

## ENGINE

Emission Regulation	Tier 3
Manufacturer	Cummins
Model	QSL9.3
Rated Power	180 kW (241 hp / 245 ps) @ 2,200 rpm
Rated Net Power	168 kW (225 hp / 228 ps) @ 2,200 rpm
Peak Torque	1,187 N·m @ 1,300 rpm
Displacement	9.3 L
Number of Cylinder	6
Aspiration	Turbocharged & Air-to-air intercooled

## TRANSMISSION

Transmission Type	Planetary, power shift
Torque Converter	Double stage, four elements
Maximum Travel Speed, fwd	40 km/h
Maximum Travel Speed, rev	16 km/h
Number of Speed, fwd	2
Number of Speed, Rev	1

## AXLES

Differential Front Type	Conventional
Differential Rear Type	Conventional
Axle Oscillation	± 10°

## STEERING

Steering Configuration	Articulated
Steering Relief Pressure	21 MPa

## BRAKES

Service Brake Type	Caliper disc brake
Service Brake Actuation	Air over hydraulic
Parking Brake Type	Drum
Parking Brake Actuation	Manual air control

## HYDRAULIC SYSTEM

Main Pump Type	Gear
Main Relief Pressure	24 MPa
Raise	5.2 s
Dump Time	1.1 s
Float Down Time	3.0 s
Fastest Total Cycle Time	9.3 s

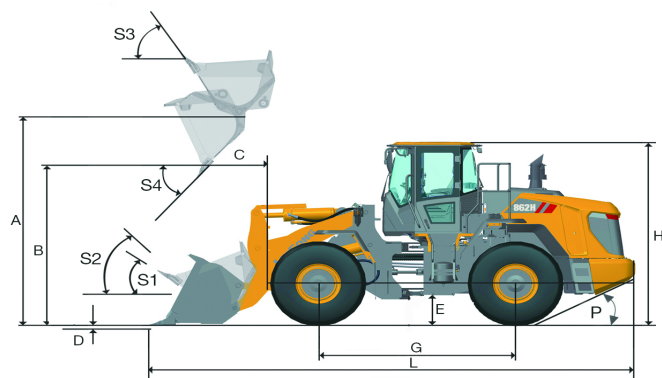

## LOADER ARM PERFORMANCE WITH STANDARD BUCKET 4.0 m<sup>3</sup>

Tipping Load - Straight (ISO 14397-1:2007)	17,110 kg
Tipping Load - Full Turn (ISO 14397-1:2007)	14,610 kg
Bucket Breakout Force	178 kN
A Maximum Hinge Pin Height	4,530 mm
B Dump Clearance at Full Height Discharge	3,303 mm
C Dump Reach at Full Height Discharge	1,072 mm
D Maximum Digging Depth, Bucket Level	89 mm
S <sub>1</sub> Rollback at Ground Level	44.3 °
S <sub>2</sub> Bucket Rollback at Carry	48 °
S <sub>3</sub> Bucket Rollback at Maximum Height	62.4 °
S <sub>4</sub> Maximum Dump Angle at Full Height	45 °

## BUCKET PERFORMANCE

Reference Bucket	3.0 - 6.0 m <sup>3</sup>
------------------	--------------------------

## DIMENSIONS

E Ground Clearance	460 mm
G Wheelbase	3,550 mm
H Cab Height	3,550 mm
J Wheel Tread	2,280 mm
K Width Over Tires	2,980 mm
L Length with Bucket Down	8,849 mm
M Turn Angle, Either Side	38 °
P Rear Angle of Departure	29 °
R <sub>1</sub> Turning Radius, Bucket Carry	7,490 mm
R <sub>2</sub> Turning Radius, Outside of Tire	6,650 mm
W Width Over Bucket	3,216 mm

## TIRES

Tire Size	26.5-25-28PR/TT L-3
-----------	---------------------

## OPERATING WEIGHTS

Operating Weight	20,500 kg
------------------	-----------

## SERVICE CAPACITY

Fuel Tank	330 L
Engine Oil	28 L
Cooling System	35 L
Hydraulic System	273 L
Transmission and Torque Converter	45 L
Axles, (F/R)	43 / 43 L

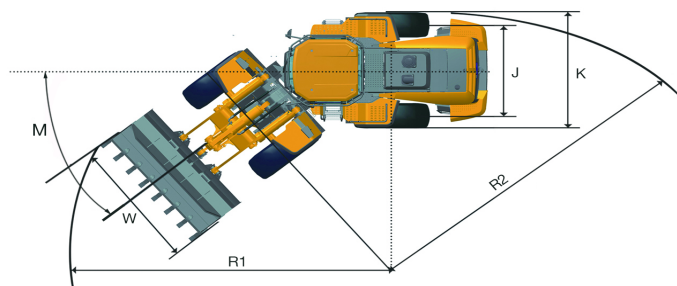

Guangxi Liugong Machinery Co., Ltd.

No. 1 Liutai Road, Liuzhou, Guangxi 545007, PR China  
T: +86 772 3886124 E: overseas@liugong.com  
www.liugong.com

Specifications and designs are subject to change without notice. Machines shown may include optional equipment. Liugong standard and optional equipment may vary from region to region. Please consult your Liugong dealer for information specific to your area. Engine power kW is converted to horsepower (1 kW=1.3596 ps and 1 kW=1.3410 hp) in this file.

06/2022 Designed by LiuGong