

MAX. PAYLOAD: 4999kg (11001 lb)
 MAX. LIFT HEIGHT: 8.1 metres (26ft 7in)

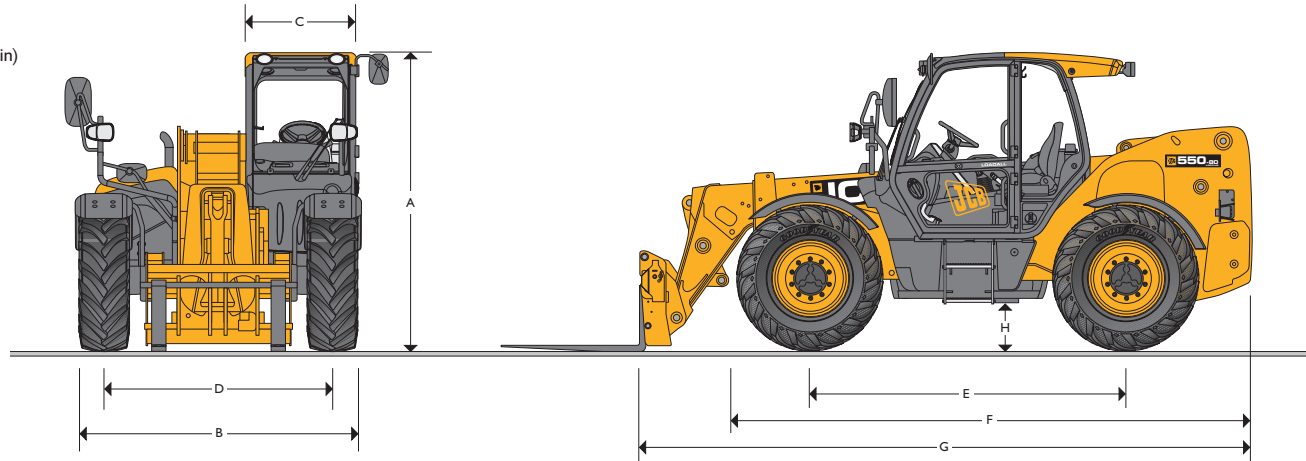

STATIC DIMENSIONS

A	Overall height	m (ft-in)	2.59 (8-6)
B	Overall width (over tyres)*	m (ft-in)	2.42 (7-11)
C	Inside width of cab	m (ft-in)	0.94 (3-1)
D	Front track	m (ft-in)	1.98 (6-6)
E	Wheelbase	m (ft-in)	2.75 (9-0)
F	Overall length to front of tyres	m (ft-in)	4.42 (14-6)
G	Overall length to front of carriage	m (ft-in)	5.27 (17-3)
H	Ground clearance	m (ft-in)	0.40 (1-4)
	Carriage rollback angle	degrees	47.0
	Carriage dump angle	degrees	33.0
	Weight	kg (lb)	10150 (22377)
	Tyres		440/80R24

*Dependant upon tyre specified.

ENGINE

Manufacturer		JCB
Displacement	litres (in ³)	4.4 (269)
No. of cylinders		4
Bore size	mm (in)	103 (4.05)
Stroke	mm (in)	132 (5)
Aspiration		TCA
Power rating		
Power @ 2200rpm	kW (hp)	97 (130)
Torque rating		
Torque @ 1500rpm	Nm (lb/ft)	532 (392)

LIFT PERFORMANCE

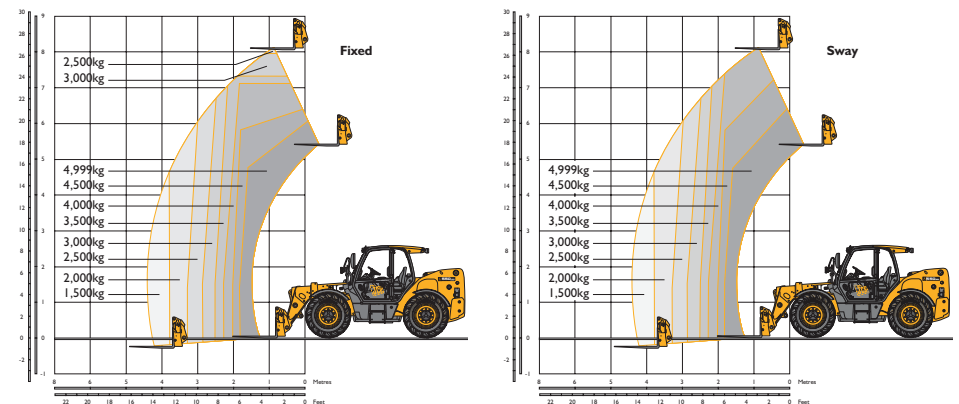

LIFT PERFORMANCE

Maximum lift capacity	kg (lb)	4999 (11001)
Lift capacity to full height	kg (lb)	2500 (5512) Fixed 4000 (8818) Sway
Lift capacity at full reach	kg (lb)	1500 (3307)
Lift height	mm (ft-in)	8.1 (26.7)
Reach at maximum lift height	mm (ft-in)	0.92 (3-0)
Maximum forward reach	mm (ft-in)	4.47 (14-8)
Reach with 1 tonne load	mm (ft-in)	4.47 (14-8)
Placing height	mm (ft-in)	7.45 (24-5)

Complies with stability test EN 1459 Annex B.

TRANSMISSION

JCB powershift transmission incorporating torque converter, bevel box and a 3 speed powershift gearbox in one resiliently mounted unit. A combined steering column mounted switch incorporating directional control and 3 forward and 3 reverse powershift gears. Travel speed 22kph (dependant upon tyre selection). Permanent 4 wheel drive. Switchable automatic transmission disconnect.

Front and rear drive axles: Epicyclic hub reduction drive/steer axles with torque proportioning differentials.

BRAKES

Service brakes: Hydraulically activated power brakes, self-adjusting, oil-immersed in-board multi-disc type on front and rear axles.

Parking brake: Hand operated oil immersed disc type.

BOOM AND CARRIAGE

Boom is manufactured from high tensile steel. Low maintenance, hard wearing pads. JCB Q-fit self-levelling carriage with lever operated pin locking accepts pallet forks and a wide range of attachments. One boom end auxiliary hydraulic service fitted as standard.

SAFETY CHECK VALVES

Fitted to carriage tilt, telescopic and boom lift rams.

SERVICE CAPACITIES

Fuel tank	litres (UK gal)	146 (32.1)
Hydraulic tank	litres (UK gal)	112 (24.6)
Coolant	litres (UK gal)	23 (5.1)

ELECTRICS

12 v negative earth. 110 AH battery. Full road lighting. Reversing light. Direction indicators. Hazard warning. Reverse alarm.

STEERING

Hydrostatic power steering with power track rods on both axles.

Three steer mode options: front wheel steer; all wheel steer; crab steer: operated from in the cab by a selection switch, with automatic alignment.

HYDRAULICS

Operating system pressure		260 (3770)
Main hydraulics	ltrs/min	140
Pump		Variable
Loader controls		Cab mounted single lever joystick
Hydraulic cycle times		seconds
Lift		7.4
Lower		5.9
Extend		8.3
Retract		5.9
Bucket dump		2.8
Bucket crowd		3.0

DELUXE CAB

Quiet, safe and comfortable cab conforms to ROPS ISO 3471 and FOPS ISO 3449. Tinted glass all round with laminated front and roof screen. Roof bars, front, rear and roof screen wash/wipe and heater/screen demister. Opening rear window. Audio-visual warning system for coolant temperature, water in fuel, engine oil pressure, air cleaner, battery charge, transmission oil temperature and pressure. Brake charge, hourmeter and road speed indicator. Engine temperature, fuel gauge and clock. Adjustable steer column with stalk bar powershift change and forward reverse shuttle. Floor mounted throttle pedal. Adjustable deluxe suspension seat with adjacent park brake. Automatic eye level audio-visual load moment indicator warning system receiving a signal from a load sensor on the rear axle. This system continuously monitors the machine's forward stability and leaves the operator in control at all times.

Hydraulic controls:

Cab mounted single lever servo joystick, incorporating forward/neutral/reverse, with progressive extend/retract and auxiliary incorporating constant flow facility.

OPTIONS AND ACCESSORIES

Options: Front and rear working lights, rotating flashing beacon, air suspension seat, roof and front screen blind, radio kit, 2 speed and intermittent front wash/wipe, high flow auxiliary, variable speed fan and reversing fan as standard, 2nd boom auxiliary, fire extinguisher, air conditioner, carriage options available – contact your local dealer.

Attachments: Contact your local dealer for details of the comprehensive range.

Adaptive load control for EU territories conforms to EN15000.



**ООО "Предприятие "Стройкомплект" - официальный дилер спецтехники JCB
в Уральском, Сибирском регионах и на Дальнем Востоке
Телефон бесплатной горячей линии: 8 800 700 5 066 www.sk.l.ru**

